

## DJANGO ALUMINUM 29

ITEMS	#SERVICE KIT	DESCRIPTION
1	KFC01302	Double cable guide / shock plate
2	KFC19047	Spacer/Bolt Kit SB157 ChainGuide
3	KFC01301	Pivot kit Shaft Django Alloy Black
4	KFC01303	Split pivot Alloy Shock bolt black
5	KFC11051	Derailleur Hanger Split Pivot 12x142/148
6	KFC01304	Bearing kit Split pivot
7	KFC19010	Rear Axle SuperBoost157*12mm/209.5mm

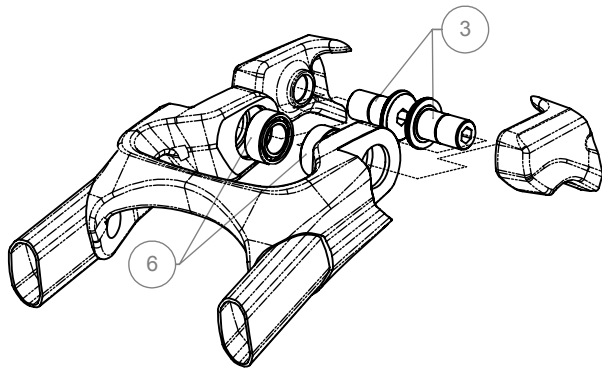

**BL PIVOT**

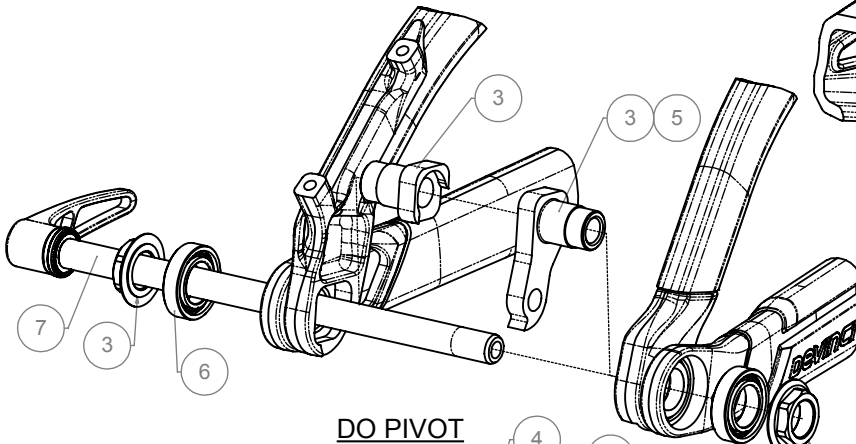

**DO PIVOT**

**CL PIVOT**

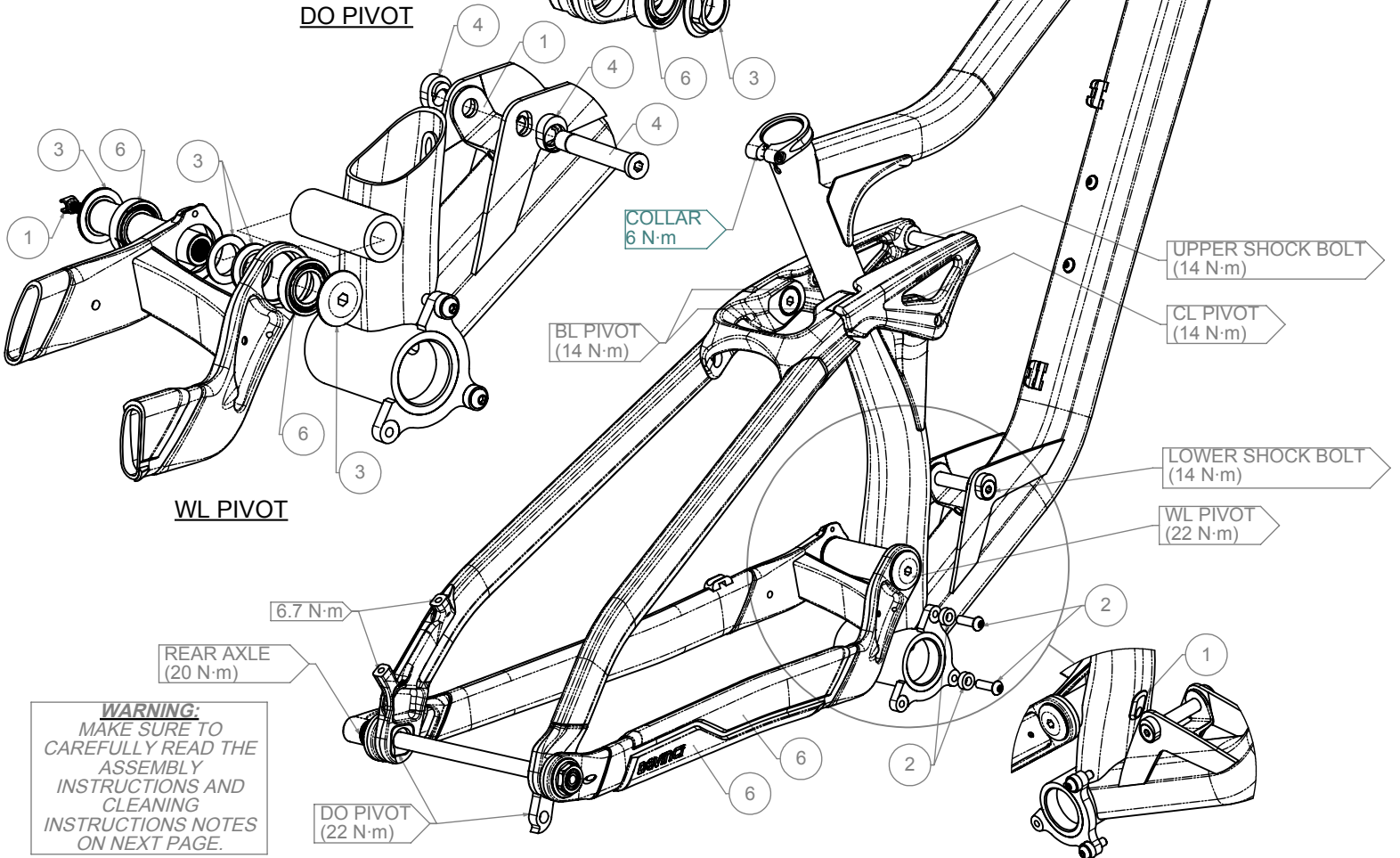

**WL PIVOT**

COLLAR  
6 N-m

BL PIVOT  
(14 N-m)

UPPER SHOCK BOLT  
(14 N-m)

CL PIVOT  
(14 N-m)

LOWER SHOCK BOLT  
(14 N-m)

WL PIVOT  
(22 N-m)

REAR AXLE  
(20 N-m)

DO PIVOT  
(22 N-m)

**WARNING:**  
MAKE SURE TO CAREFULLY READ THE ASSEMBLY INSTRUCTIONS AND CLEANING INSTRUCTIONS NOTES ON NEXT PAGE.

### ASSEMBLY INSTRUCTIONS:

- 1- THOROUGHLY CLEAN THE INTERIOR OF EACH BEARING HOUSING TO REMOVE ANY DIRT OR OLD GREASE;
- 2- APPLY HIGH QUALITY WATERPROOF GREASE ON THE INSIDE FACE AND INSIDE DIAMETER OF ALL BEARING HOUSINGS BEFORE PRESS-FIT;
- 3- APPLY HIGH QUALITY WATERPROOF GREASE TO ALL PIVOT PARTS THAT CONTACT WITH THE INNER DIAMETER OF THE BEARINGS.
- 4- APPLY HIGH QUALITY WATERPROOF GREASE TO ALL NON-THREADED METAL-TO-METAL INTERFACES (EX.: PLANAR FACE OF THE PIVOT SPACER THAT CONTACTS THE LATERAL FACES OF THE FRONT TRIANGLE WL PIVOT). THESE INSTRUCTIONS ALSO APPLY TO THE SHOCK ASSEMBLY;
- 5- UNLESS OTHERWISE SPECIFIED, APPLY BLUE LOCTITE 242 ON ALL THREADS BEFORE ASSEMBLY TO THE SPECIFIED TORQUE VALUE;
- 6- TO PREVENT DAMAGE TO THE FRAME, THE SEATPOST MUST HAVE A MINIMUM INSERTION IN THE SEAT TUBE.

### ALUMINIUM FRAME:

SMALL / MEDIUM / LARGE / X-LARGE - 100mm INSERTION

\*ALWAYS VERIFY CONNECTOR CLEARANCE BEFORE FULLY INSERTING A DROPPER POST.

7- FRG ADJUSTABLE: THIS DESIGN ALLOWS RIDERS TO CHOOSE BETWEEN A LOW OR HIGH POSITION. WITH FRG ADJUSTABLE TECHNOLOGY, YOU CAN FINE-TUNE YOUR RIDE TO PERSONAL TASTES OR SPECIFIC TRAIL TYPES USING A FLIP-FLOP PIVOT MECHANISM THAT SLIGHTLY CHANGES THE BIKE'S GEOMETRY AS SHOWN BELOW.

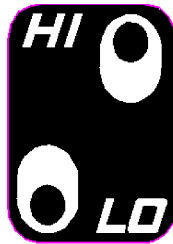

### CLEANING INSTRUCTIONS:

IT IS A WELL KNOWN FACT THAT A CLEAN BIKE PERFORMS BETTER. DEVINCI RECOMMENDS WASHING YOUR BIKE REGULARLY USING A BRUSH AND SOAPY WATER. HOWEVER, DEVINCI DO NOT RECOMMEND THE USE OF A PRESSURE WASHER, SINCE THIS MAY SIGNIFICANTLY REDUCE THE SERVICE LIFE OF BALL BEARINGS. EVEN THOUGH OUR BALL BEARINGS ARE EQUIPPED WITH HIGH QUALITY DOUBLE-LIP SEALS, HIGH PRESSURE WATER CAN STILL PASS THESE SEALS AND REMOVE THE GREASE INSIDE THE BEARING. THIS MAY CAUSE PREMATURE CORROSION AND WEAR OF THE BALL BEARINGS.

# DJANGO 29

Carbon / Aluminum

2020

## Frame

<i>Axle Length:</i>	209mm
<i>Rear Hub Spacing:</i>	12 x 157 mm
<i>Chain Guide:</i>	ISCG 05
<i>Recommended Fork Offset:</i>	44 mm, 42mm
<i>Seat Post Diameter:</i>	31.6 mm
<i>Seat Collar Diameter:</i>	37 mm / 34.9 mm
<i>Upper Headset:</i>	ZS 44/28
<i>Lower Headset:</i>	ZS 56/40
<i>Rear Brake:</i>	Direct Mount 180 mm / MAX 200mm

## Drivetrain

<i>Crankset type:</i>	SuperBoost 1X
<i>Minimum Q-Factor:</i>	173 mm
<i>Chain Line:</i>	56.5 mm
<i>Minimum Chain Ring:</i>	30T
<i>Maximum Chain Ring:</i>	34T
<i>Bottom Bracket:</i>	BSA 73 mm

## Rear Shock

<i>Dimension:</i>	190 mm x 45 mm
<i>Piggy Back Compatibility:</i>	YES (see note below)*
<i>Coil Shock Compatibility:</i>	YES
<i>Upper Hardware:</i>	10mm x 40 mm
<i>Lower Hardware:</i>	10mm x 40 mm

\*Not compatible with water bottle

For more information contact [service@devinci.com](mailto:service@devinci.com)