

CX 3



FRAME	CX MONOCOQUE CARBON
SIZES	S - M - L - XL
FORK	DEVINCI CARBON CS
REAR SHOCK	-
SHOCK PUMP	-
HEADSET	TH NO. 16/CC
REAR DERAILLEUR	SHIMANO ULTEGRA 6600
FRONT DERAILLEUR	SHIMANO ULTEGRA 6600
CRANKSET	SHIMANO ULTEGRA 6600 52/39T
CHAIN GUIDE	-
FRONT SHIFTER	SHIMANO ULTEGRA 6600
REAR SHIFTER	SHIMANO ULTEGRA 6600
CASSETTE	CASSETTE ULTEGRA 6600 10S 12-25T
CHAIN	SHIMANO 105 5600
PEDALS	-
FRONT WHEEL	MAVIC KSYRIUM EQUIPE
REAR WHEEL	MAVIC KSYRIUM EQUIPE
TIRES	MAXXIS XENITH HORS CATÉGORIE 700X23C 120TPI FOLDABLE
BRAKES	SHIMANO ULTEGRA 6600
STEM	V2 PRO 31.8MM
HANDLEBAR	V2 GYRO AEROBAR BUTTED 6061 31.8MM
GRIPS, TAPE	VELO GEL CORK
SADDLE	SELLE ITALIA SLR XP TRANS AM
SEATPOST	V2 FUSION CARBON 31.6MM

CX MONOCOQUE CARBON

CX 1, CX 2, CX 3

Light. Rigid. Comfortable. Since its introduction, magazines such as *Bicycling* and *Vélo*mag have waxed lyrical about the Cx frame. One of the world's leading bike test laboratories, Germany's EFB, has also given it top marks. The Cx frame integrates Optimum C6 monocoque carbon for strength and comes with an oversized chainstay to increase rigidity and responsiveness when pedaling. A pure racing thoroughbred, the Cx frame will give you an unfair advantage over the rest of the pack.

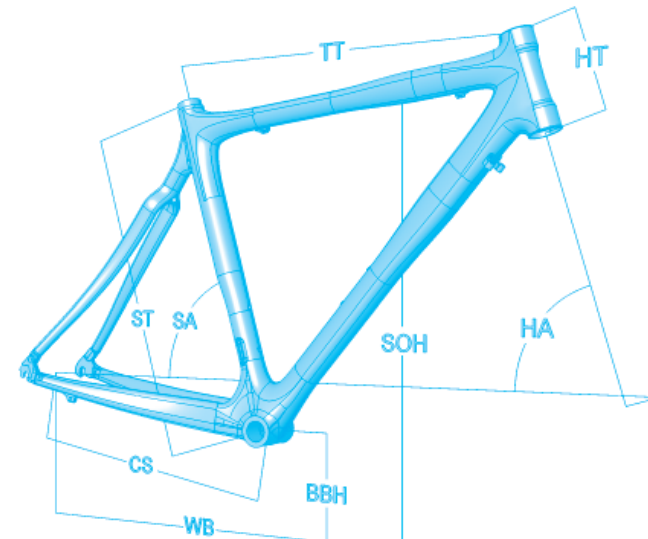

	ST		SA		HA		TT		CS		WB		BBH		SOH		HT	
	cm	in	deg	deg	mm	in	mm	in	mm	in	mm	in	mm	in	mm	in	mm	in
S	45.0	17.7	75.0	72.0	520	20.5	410	16.1	978	38.5	270	10.6	706	27.8	120	4.7		
M	50.0	19.7	74.0	73.0	540	21.3	410	16.1	980	38.6	270	10.6	744	29.3	140	5.5		
L	54.0	21.2	73.5	73.0	560	22.0	410	16.1	995	39.2	270	10.6	778	30.6	170	6.7		
XL	58.0	22.8	73.0	73.0	585	23.0	410	16.1	1015	40.0	270	10.6	809	31.9	200	7.9		

DEVINCI



devinciIntelligence

DEVINCI.COM