

FRANTIK 3



FRAME	FRANTIK
SIZES	S - M
FORK	ROCK SHOX TOTEM SOLO AIR 180MM
REAR SHOCK	FOX DHX 5.0
SHOCK PUMP	DEVINCI HIGH PRESSURE
HEADSET	FSA ORBIT EXTREME PRO 1.5
REAR DERAILLEUR	SRAM X.O
FRONT DERAILLEUR	SRAM X.9
CRANKSET	RACE FACE DIABOLUS X-TYPE 36/24T
CHAIN GUIDE	E13 DRS
FRONT SHIFTER	SRAM X.O
REAR SHIFTER	SRAM X.O
CASSETTE	SRAM POWER GLIDE II 990 9S 11-32T
CHAIN	SRAM PC 991
PEDALS	DAREDEVIL FLAT
FRONT WHEEL	MAVIC DEEMAX DISC
REAR WHEEL	MAVIC DEEMAX DISC
TIRES	MAXXIS HI-ROLLER 26X2.5" TUBELESS
BRAKES	AVID JUICY 7 CARBON 203MM ROTOR HYDRAULIC DISC
STEM	DAREDEVIL 1.5
HANDLEBAR	RACE FACE DIABOLUS RISERBAR 31.8MM
GRIPS, TAPE	VELO LOCK-ON
SADDLE	DAREDEVIL AM TITANIUM
SEATPOST	RACE FACE DIABOLUS 31.6MM

FRANTIK

FRANTIK 1, FRANTIK 2, FRANTIK 3

Whether you're busting out and throwing it down for the gallery or stomping a sick air with ease in front of your smack-talking friends, this burly frame is designed for the Slopestyle world and for real life, where not all landings are butter-smooth. Constructed with reinforced Optimum X-2 tubing and a one point five standard compatible head tube, the frame also boasts a 150mm through axle freehub and 165mm of plush rear travel. It's what you need to get bigger tricked-out air. Period.

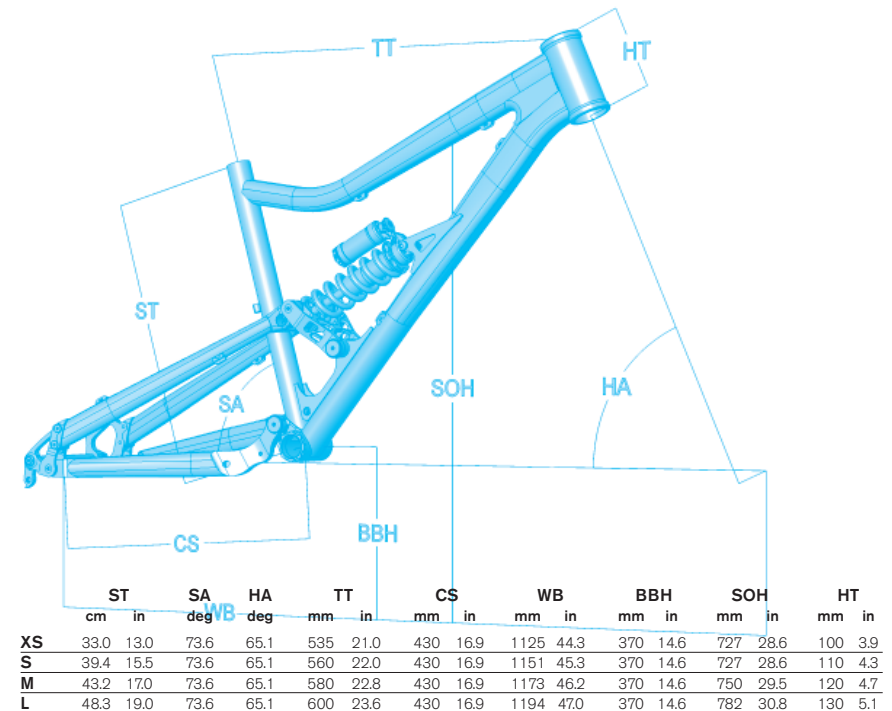

devinci



DEVINCI.COM