



- 06** FV6830101 XSmall
FV6830201 Small
FV6830301 Medium
FV6830401 Large



SPECIFICATIONS

Frame	Optimum 61 dual suspension all mountain Lite frame
Color	Copper Orange
Available Sizes	xs-s-m-l
Weight	12.8 kg / 28.1 lb
Fork	Fox Talas RL 90-110-130mm
Rear Shock	Fox Float RP3
Headset	TH Industries No.9MCup/TH
Rear Derailleur	Shimano XTR M960
Front Derailleur	Shimano Deore XT M761
Crankset	Shimano Deore XT M760 44/32/22T
Chainguide	-
Shifters	Shimano Deore XT M765
Cassette	Shimano Deore XT M760 9s 11-32T
Chain	Shimano HG73
Bottom Bracket	Shimano Deore XT M760
Pedals	Crank brother Candy C
Front Hub	-
Rear Hub	-
Rims	-
Spokes	-
Wheels	Mavic Crossland disc
Tires	Michelin XCR directional 26x2.0"
Brakes	Shimano Deore XT M765 7" front 6" rear hydraulic disc
Brake Levers	Shimano Deore XT M765
Stem	Daredevil AM 31.8mm
Handlebar	Daredevil riserbar 25mm butted 6061 31.8mm
Grips / Tape	Gel lock-on
Saddle	Selle Italia C2 carbon trans am special edition
Seat Post	Daredevil 27.2mm
Seat Collar	Devinci quick release

Notes



OPTIMUM 61 DUAL SUSPENSION ALL MOUNTAIN LITE FRAME

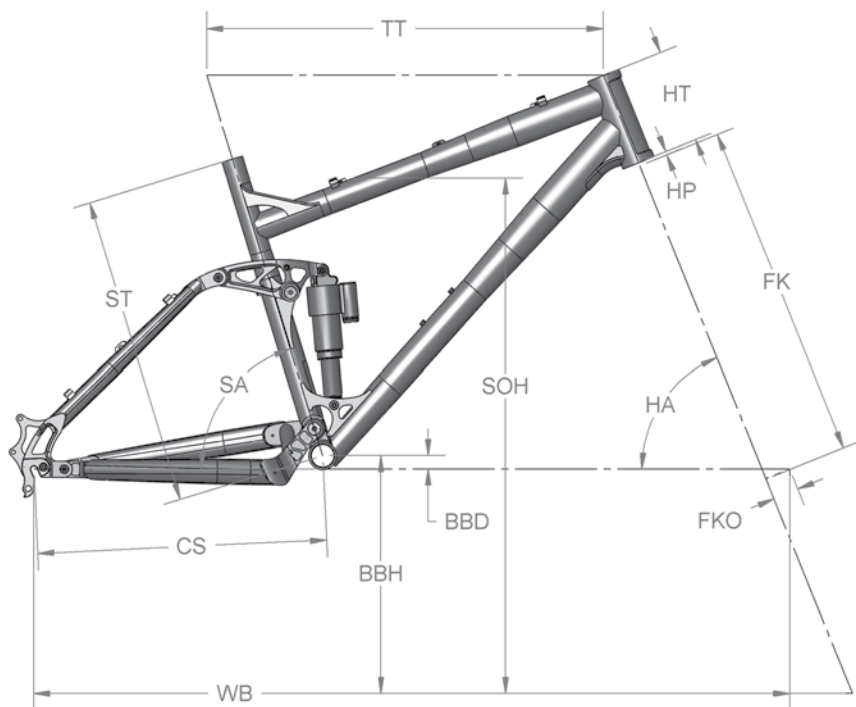

FRAME TECHNICAL SPECIFICATIONS

Seat post diameter	27.2mm
Seat collar diameter	31.8mm
Headset diameter	1 1/8"
Headset type	Semi-integrated
Fork type	120mm to 130mm
Brake type	Disk
Front derailleur diameter	34.9mm
Front derailleur cable route	Top
Front derailleur type	Down-swing
Bottom bracket shell width	73mm
Freehub width	135mm
Shock length	200mm
Shock travel	50mm
Shock pivot width top	25.4mm
Shock pivot width bottom	35.0mm
Shock bolt diameter	8mm
Rear wheel travel	105 / 125 / 145mm
Tire maximum clearance	26 x 2.35
Rear derailleur hanger type	MFD05013
Rear rack eyelet	-
Fender eyelet	-
Weight	2.60 kg / 5.7 lb

FRAME GEOMETRY

	ST		SA		HA		TT		CS		WB		BBH		SOH		HT		BBD		FK		FKO		HP			
	cm	in	deg	deg	mm	in	mm	in	mm	in	mm	in	mm	in	mm	in	mm	in	mm	in	mm	in	mm	in	mm	in		
XS	38.0	15.0	72.8	67.3	540.0	21.3	430.0	16.9	1079.0	42.5	357.0	14.1	725.0	28.5	110.0	4.3	22.0	0.9	505.0	19.9	38.0	1.5	5.0	0.2				
S	42.0	16.5	72.8	67.3	565.0	22.2	430.0	16.9	1105.0	43.5	357.0	14.1	730.0	28.7	120.0	4.7	22.0	0.9	505.0	19.9	38.0	1.5	5.0	0.2				
M	46.0	18.1	72.8	67.8	590.0	23.2	430.0	16.9	1126.0	44.3	357.0	14.1	760.0	29.9	140.0	5.5	22.0	0.9	505.0	19.9	38.0	1.5	5.0	0.2				
L	49.5	19.5	72.8	68.3	615.0	24.2	430.0	16.9	1146.0	45.1	357.0	14.1	788.0	31.0	160.0	6.3	22.0	0.9	505.0	19.9	38.0	1.5	5.0	0.2				

SIZING CHART

Height (cm)	144	146	148	150	152	154	157	159	161	163	165	168	170	172	174	176	178	180	182	184	186	188	190	192	194	196	198	200	202	
Inseam (cm)	68	69	70	71	72	73	74	75	76	77	78	79	80	81	82	83	84	85	86	87	88	89	90	91	92	93	94	95	96	
XS																														
S																														
M																														
L																														
Height (inch)	4'8"	4'10"	4'11"	4'11"	5'0"	5'1"	5'1"	5'2"	5'3"	5'4"	5'5"	5'6"	5'7"	5'7"	5'8"	5'9"	5'10"	5'11"	6'0"	6'0"	6'1"	6'2"	6'3"	6'4"	6'5"	6'5"	6'6"	6'7"	6'7"	
Inseam (inch)	26 3/4	27 1/4	27 3/4	28	28 1/4	28 3/4	29 1/4	29 1/2	30	30 1/4	30 3/4	31	31 1/2	32	32 1/4	32 3/4	33	33 1/2	33 3/4	34 1/4	34 3/4	35	35 1/2	35 3/4	36 1/4	36 3/4	37	37 1/2	37 3/4	

TO MEASURE INSEAM

You must be standing on a hard surface, in bare feet (or light cycling socks). Ideally, you will be wearing cycling shorts or long tights.

Place the feet so the medial ankle bones are approximately 5 cm apart. This can easily be gauged by slipping the width of the measuring tape case between the ankle bones.

The metric tape should be centered in the crotch. With the tape firmly in the crotch, pull with about the same pressure that you would feel if you were sitting on a bicycle seat. Pull the measuring tape to the floor for the inseam measurement.

TO MEASURE HEIGHT

You must be standing on a hard surface, in bare feet (or light cycling socks).

Place the feet so the medial ankle bones are approximately 5 cm apart. This can easily be gauged by slipping the width of the measuring tape case between the ankle bones.

