

OPTIMUM 61 CROSS-COUNTRY FRAME

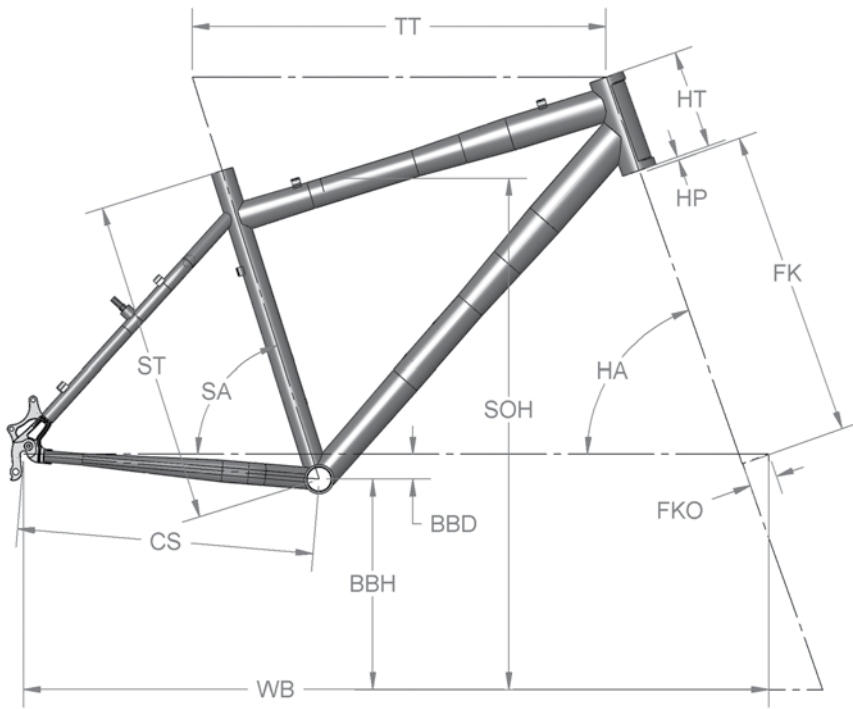

FRAME TECHNICAL SPECIFICATIONS

Seat post diameter	27.2 mm
Seat collar diameter	31.8 mm
Headset diameter	1 1/8"
Headset type	Semi-integrated
Fork type	80 to 100 mm
Brake type	"V-Brake"-Disk
Front derailleur diameter	31.8 mm
Front derailleur cable route	Top
Front derailleur type	Down-swing
Bottom bracket shell width	73 mm
Freehub width	135 mm
Shock length	NA
Shock travel	NA
Shock pivot width top	NA
Shock pivot width bottom	NA
Shock bolt diameter	NA
Rear wheel travel	NA
Tire maximum clearance	26 x 2.1
Rear derailleur hanger type	MFD205
Rear rack eyelet	NA
Fender eyelet	NA
Weight	1.43 kg / 3.15 lb

FRAME GEOMETRY

	ST		SA		HA		TT		CS		WB		BBH		SOH		HT		BBD		FK		FKO		HP			
	cm	in	deg	deg	mm	in	mm	in	mm	in	mm	in	mm	in	mm	in	mm	in	mm	in	mm	in	mm	in	mm	in		
XS	35.5	14.0	74.0	69.5	533.0	21.0	420.0	16.5	1043.0	41.1	294.0	11.6	674.0	26.5	110.0	4.3	35.0	1.4	435.0	17.1	39.0	1.5	5.0	0.2				
S	40.6	16.0	73.5	70.0	559.0	22.0	420.0	16.5	1043.0	41.1	294.0	11.6	700.0	27.6	120.0	4.7	35.0	1.4	435.0	17.1	39.0	1.5	5.0	0.2				
M	45.7	18.0	72.5	70.5	584.0	23.0	420.0	16.5	1054.0	41.5	294.0	11.6	733.0	28.9	140.0	5.5	35.0	1.4	435.0	17.1	39.0	1.5	5.0	0.2				
L	50.8	20.0	72.0	71.0	610.0	24.0	420.0	16.5	1069.0	42.1	294.0	11.6	767.0	30.2	160.0	6.3	35.0	1.4	435.0	17.1	39.0	1.5	5.0	0.2				
XL	55.9	22.0	71.5	71.5	629.0	24.8	420.0	16.5	1077.0	42.4	294.0	11.6	800.0	31.5	180.0	7.1	35.0	1.4	435.0	17.1	39.0	1.5	5.0	0.2				

SIZING CHART

	144	146	148	150	152	154	157	159	161	163	165	168	170	172	174	176	178	180	182	184	186	188	190	192	194	196	198	200	202
Height (cm)	144	146	148	150	152	154	157	159	161	163	165	168	170	172	174	176	178	180	182	184	186	188	190	192	194	196	198	200	202
Inseam (cm)	68	69	70	71	72	73	74	75	76	77	78	79	80	81	82	83	84	85	86	87	88	89	90	91	92	93	94	95	96
XS																													
S																													
M																													
L																													
XL																													
Height (inch)	4'8"	4'10"	4'11"	4'11"	5'0"	5'1"	5'1"	5'2"	5'3"	5'4"	5'5"	5'6"	5'7"	5'7"	5'8"	5'9"	5'10"	5'11"	6'0"	6'0"	6'1"	6'2"	6'3"	6'4"	6'5"	6'5"	6'6"	6'7"	6'7"
Inseam (inch)	26 3/4	27 1/4	27 3/4	28	28 1/4	28 3/4	29 1/4	29 1/2	30	30 1/4	30 3/4	31	31 1/2	32	32 1/4	32 3/4	33	33 1/2	33 3/4	34 1/4	34 3/4	35	35 1/2	35 3/4	36 1/4	36 3/4	37	37 1/2	37 3/4

TO MEASURE INSEAM

You must be standing on a hard surface, in bare feet (or light cycling socks). Ideally, you will be wearing cycling shorts or long tights.

Place the feet so the medial ankle bones are approximately 5 cm apart. This can easily be gauged by slipping the width of the measuring tape case between the ankle bones.

The metric tape should be centered in the crotch. With the tape firmly in the crotch, pull with about the same pressure that you would feel if you were sitting on a bicycle seat. Pull the measuring tape to the floor for the inseam measurement.

TO MEASURE HEIGHT

You must be standing on a hard surface, in bare feet (or light cycling socks).

Place the feet so the medial ankle bones are approximately 5 cm apart. This can easily be gauged by slipping the width of the measuring tape case between the ankle bones.

