



- 06** FV6340201 Small
- FV6340301 Medium
- FV6340401 Large
- FV6340501 XLarge



SPECIFICATIONS



Frame	Optimum 61 touring and hybrid frame with disc brake mount
Color	Ferrari Red
Available Sizes	s-m-l-xl
Weight	11.2 kg / 24.6 lb
Fork	Devinci Carbon As aluminum steerer with disc brake hanger
Rear Shock	-
Headset	TH Industries IS-3E
Rear Derailleur	Shimano Deore LX M571
Front Derailleur	Shimano R443
Crankset	Truvativ Touro power spline 52/42/30T
Chainguide	-
Shifters	Shimano R440
Cassette	Shimano HG50 9s 11-32T
Chain	Shimano HG53
Bottom Bracket	Truvativ power spline
Pedals	Wellgo alloy
Front Hub	Formula disc
Rear Hub	Formula disc
Rims	Mach 1 240
Spokes	DT Swiss stainless
Wheels	-
Tires	Kenda Kwest 60tpi, L3R, K-shield, 700x32C
Brakes	Promax TX-122
Brake Levers	Promax XL-96
Stem	Ritchey 31.8mm
Handlebar	V2 Gyro riserbar 25mm butted 6061 31.8mm
Grips / Tape	Gel lock-on
Saddle	Selle Italia XO trans am
Seat Post	Ritchey 27.2mm
Seat Collar	Devinci bolt

Notes





OPTIMUM 61 TOURING AND HYBRID FRAME

with disc brake mount

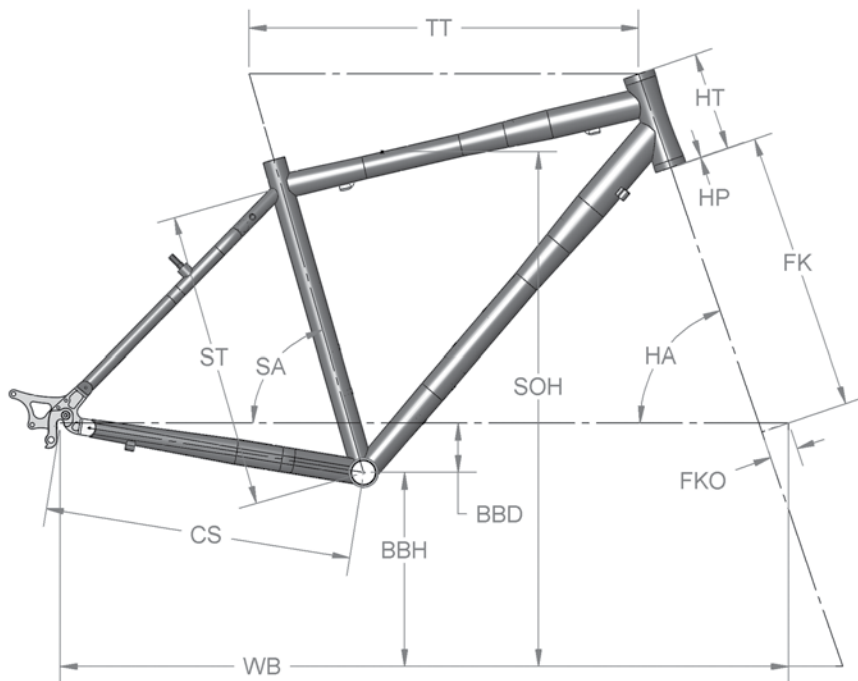

FRAME TECHNICAL SPECIFICATIONS

Seat post diameter	27.2 mm
Seat collar diameter	31.8 mm
Headset diameter	1 1/8"
Headset type	Integrated
Fork type	Rigid
Brake type	"V-Brake" / Disk
Front derailleur diameter	31.8 mm
Front derailleur cable route	Bottom
Front derailleur type	Down-swing
Bottom bracket shell width	68 mm
Freehub width	135 mm
Shock length	-
Shock travel	-
Shock pivot width top	-
Shock pivot width bottom	-
Shock bolt diameter	-
Rear wheel travel	-
Tire maximum clearance	700 - 35
Rear derailleur hanger type	MFD205
Rear rack eyelet	Dropout - Seatstay
Fender eyelet	Yes
Weight	1.40 kg / 3.1 lb

FRAME GEOMETRY

	ST		SA		HA		TT		CS		WB		BBH		SOH		HT		BBD		FK		FKO		HP	
	cm	in	deg	deg	mm	in	mm	in	mm	in	mm	in	mm	in	mm	in	mm	in	mm	in	mm	in	mm	in	mm	in
S	37.0	14.6	75.0	70.5	540.0	21.3	435.0	17.1	1027.0	40.4	275.0	10.8	690.0	27.2	120.0	4.7	70.0	2.8	395.0	15.6	45.0	1.8	1.0	0.0		
M	42.0	16.5	74.0	71.0	555.0	21.9	435.0	17.1	1027.0	40.4	275.0	10.8	729.0	28.7	140.0	5.5	70.0	2.8	395.0	15.6	45.0	1.8	1.0	0.0		
L	47.0	18.5	73.5	71.0	565.0	22.2	435.0	17.1	1038.0	40.9	275.0	10.8	769.0	30.3	170.0	6.7	70.0	2.8	395.0	15.6	45.0	1.8	1.0	0.0		
XL	51.0	20.1	73.0	71.0	585.0	23.0	435.0	17.1	1055.0	41.5	275.0	10.8	800.0	31.5	200.0	7.9	70.0	2.8	395.0	15.6	45.0	1.8	1.0	0.0		

SIZING CHART

Height (cm)	144	146	148	150	152	154	157	159	161	163	165	168	170	172	174	176	178	180	182	184	186	188	190	192	194	196	198	200	202
Inseam (cm)	68	69	70	71	72	73	74	75	76	77	78	79	80	81	82	83	84	85	86	87	88	89	90	91	92	93	94	95	96
S																													
M																													
L																													
XL																													
Height (inch)	4'8"	4'10"	4'11"	4'11"	5'0"	5'1"	5'1"	5'2"	5'3"	5'4"	5'5"	5'6"	5'7"	5'7"	5'8"	5'9"	5'10"	5'11"	6'0"	6'0"	6'1"	6'2"	6'3"	6'4"	6'5"	6'5"	6'6"	6'7"	6'7"
Inseam (inch)	26 3/4	27 1/4	27 1/2	28	28 1/4	28 3/4	29 1/4	29 1/2	30	30 1/4	30 3/4	31	31 1/2	32	32 1/4	32 3/4	33	33 1/2	33 3/4	34 1/4	34 3/4	35	35 1/2	35 3/4	36 1/4	36 1/2	37	37 1/2	37 3/4

TO MEASURE INSEAM

You must be standing on a hard surface, in bare feet (or light cycling socks). Ideally, you will be wearing cycling shorts or long tights.

Place the feet so the medial ankle bones are approximately 5 cm apart. This can easily be gauged by slipping the width of the measuring tape case between the ankle bones.

The metric tape should be centered in the crotch. With the tape firmly in the crotch, pull with about the same pressure that you would feel if you were sitting on a bicycle seat. Pull the measuring tape to the floor for the inseam measurement.

TO MEASURE HEIGHT

You must be standing on a hard surface, in bare feet (or light cycling socks).

Place the feet so the medial ankle bones are approximately 5 cm apart. This can easily be gauged by slipping the width of the measuring tape case between the ankle bones.

