

TOSCA 1



FRAME	TOSCA
SIZES	XS - S - M - L - XL
FORK	DEVINCI CARBON WITH DISC BRAKE HANGER
REAR SHOCK	-
SHOCK PUMP	-
HEADSET	TH IS-3E
REAR DERAILLEUR	SHIMANO TIAGRA 4500
FRONT DERAILLEUR	SHIMANO SORA 3300
CRANKSET	TRUVATIV TOURO C 2.1 POWER SPLINE 50/36T
CHAIN GUIDE	-
FRONT SHIFTER	SHIMANO SORA 3300
REAR SHIFTER	SHIMANO SORA 3300
CASSETTE	SHIMANO HG50 8S 13-26T
CHAIN	SHIMANO HG50
PEDALS	WELLGO CLIPLESS WPD-M823
FRONT WHEEL	SHIMANO M475 DISC / MADDUX DRX4000 / DT SWISS CHAMPION
REAR WHEEL	SHIMANO M475 DISC / MADDUX DRX4000 / DT SWISS CHAMPION
TIRES	MAXXIS LOCUST CX 700X35C
BRAKES	TEKTRO ORYX 992AG
STEM	FSA OS-190LX 31.8MM
HANDLEBAR	V2 GYRO ROADBAR 6061 BUTTED 31.8MM
GRIPS, TAPE	VELO GEL CORK
SADDLE	SELLE ITALIA XO TRANS AM
SEATPOST	FSA SL-280 27.2MM

TOSCA TOSCA 1

The Tosca frame was designed with the help of Ludovic Dubau, 2005 cyclocross world champion, and was then carefully refined by Devinci engineers to make it more versatile. The frame has 30% more lateral rigidity, making it perfect for quick accelerations. The redesign included adding disk brakes for powerful braking. More affordably priced than the SL model, the Tosca is a high quality frame that's perfect for riders who want to try cyclocross.

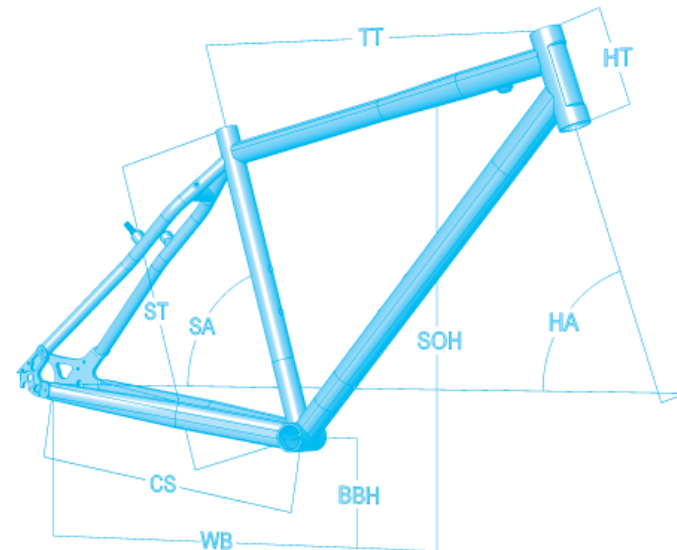

	ST		SA		HA		TT		CS		WB		BBH		SOH		HT	
	cm	in	deg	deg	mm	in	mm	in	mm	in	mm	in	mm	in	mm	in	mm	in
XS	35.0	13.8	75.0	70.0	535	21.1	435	17.1	1033	40.7	275	10.8	640	25.2	120	4.7		
S	41.0	16.1	75.0	70.5	540	21.3	435	17.1	1033	40.7	275	10.8	684	26.9	120	4.7		
M	46.0	18.1	74.0	71.0	555	21.9	435	17.1	1035	40.7	275	10.8	725	28.5	140	5.5		
L	51.0	20.1	73.5	71.0	565	22.2	435	17.1	1041	41.0	275	10.8	767	30.2	170	6.7		
XL	55.0	21.7	73.0	71.0	585	23.0	435	17.1	1056	41.6	275	10.8	803	31.6	200	7.9		

devinci



DEVINCI.COM