

# REMIX 2



<b>FRAME</b>	REMIX
<b>SIZES</b>	XS - S - M - L
<b>FORK</b>	MARZOCCHI MX PRO 120MM
<b>REAR SHOCK</b>	X-FUSION GLYDE R
<b>SHOCK PUMP</b>	-
<b>HEADSET</b>	TH NO.11
<b>REAR DERAILLEUR</b>	SHIMANO HONE M600
<b>FRONT DERAILLEUR</b>	SHIMANO HONE M601
<b>CRANKSET</b>	TRUVATIV BLAZE 2.0 HOWITZER 36/24T
<b>CHAIN GUIDE</b>	-
<b>FRONT SHIFTER</b>	SHIMANO DEORE M511
<b>REAR SHIFTER</b>	SHIMANO DEORE M511
<b>CASSETTE</b>	SHIMANO HG50 9S 11-32T
<b>CHAIN</b>	SHIMANO HG53
<b>PEDALS</b>	WELLGO LU-A18
<b>FRONT WHEEL</b>	SHIMANO HONE M600 DISC / MACH 1 MX DISC / DT SWISS CHAMPION
<b>REAR WHEEL</b>	SHIMANO HONE M600 DISC / MACH 1 MX DISC / DT SWISS CHAMPION
<b>TIRES</b>	TOMAC NEVAGAL 26X2.1"
<b>BRAKES</b>	TEKTRO AURIGA 160MM ROTOR HYDRAULIC DISC
<b>STEM</b>	DEVINCI 4 BOLT
<b>HANDLEBAR</b>	HL MT-153 RISERBAR
<b>GRIPS, TAPE</b>	VELO KRATON
<b>SADDLE</b>	DEVINCI DOUBLE DENSITY
<b>SEATPOST</b>	PROMAX SP-228 27.2MM

## REMIX

REMIX 1, REMIX 2

The new version of the Remix frame is probably the best value for your money you're likely to find anywhere. Needle bearings, four-bar linkage suspension, CNC machined parts... and it still comes in at a lower price than similar models on the market. Add to that its light aluminum tubing, coil spring shock, and, of course, Devinci's strict standards, and you get a ride that's light and exciting on rough terrain.

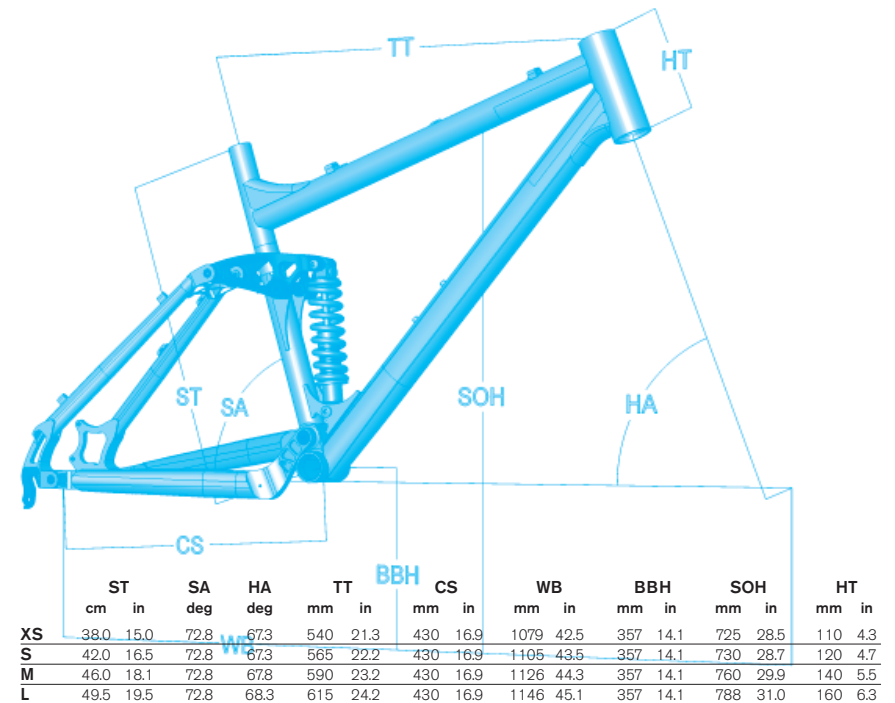

devinci



devinciIntelligence

DEVINCI.COM