

# OLLIE 2



<b>FRAME</b>	OLLIE
<b>SIZES</b>	S - M - L
<b>FORK</b>	MARZOCCHI 888 RC2 200MM
<b>REAR SHOCK</b>	FOX DHX 4.0
<b>SHOCK PUMP</b>	-
<b>HEADSET</b>	FSA ORBIT X 1.5R
<b>REAR DERAILEUR</b>	SHIMANO SAINT M800
<b>FRONT DERAILEUR</b>	SHIMANO SAINT M806
<b>CRANKSET</b>	RACE FACE DIABOLUS X-TYPE 36/24T
<b>CHAIN GUIDE</b>	E13 DRS
<b>FRONT SHIFTER</b>	SHIMANO XT M751
<b>REAR SHIFTER</b>	SHIMANO XT M751
<b>CASSETTE</b>	SHIMANO HG50 9S 11-34T
<b>CHAIN</b>	SHIMANO HG53
<b>PEDALS</b>	DAREDEVIL FLAT
<b>FRONT WHEEL</b>	DAREDEVIL DISC 20MM / MAVIC EX325 / DT SWISS CHAMPION
<b>REAR WHEEL</b>	DAREDEVIL 150MM DISC / MAVIC EX325 / DT SWISS CHAMPION
<b>TIRES</b>	MICHELIN DH COMP 24.1 26X2.5"
<b>BRAKES</b>	SHIMANO SAINT M800 203MM ROTOR HYDRAULIC DISC
<b>STEM</b>	DAREDEVIL DH
<b>HANDLEBAR</b>	DAREDEVIL DH RISERBAR 31.8MM
<b>GRIPS, TAPE</b>	VELO LOCK-ON
<b>SADDLE</b>	DAREDEVIL FR
<b>SEATPOST</b>	DAREDEVIL AM 31.6MM

## OLLIE

OLLIE 1, OLLIE 2

This frame was named "Freeride Bike of the Year" by biking mags Twenty Six and Decline, and was ridden into the top-ten at the RedBull Rampage in 2004. This year the Ollie frame is back in full force with a design especially for extreme freeriding. Constructed with our legendary Optimum X tubing and with an active suspension, courtesy of Devinci's strikingly elegant 4-bar linkage design, this bike is set up for seemingly bottomless travel at both ends. The frame is compatible with both 24 inch and 26 inch wheels, is equipped with a one point five head tube, a 150mm through axle freehub, and precision needle-bearings throughout. Every day we receive comments from riders who rave about how this frame has helped improve their experience. Now it's your turn.

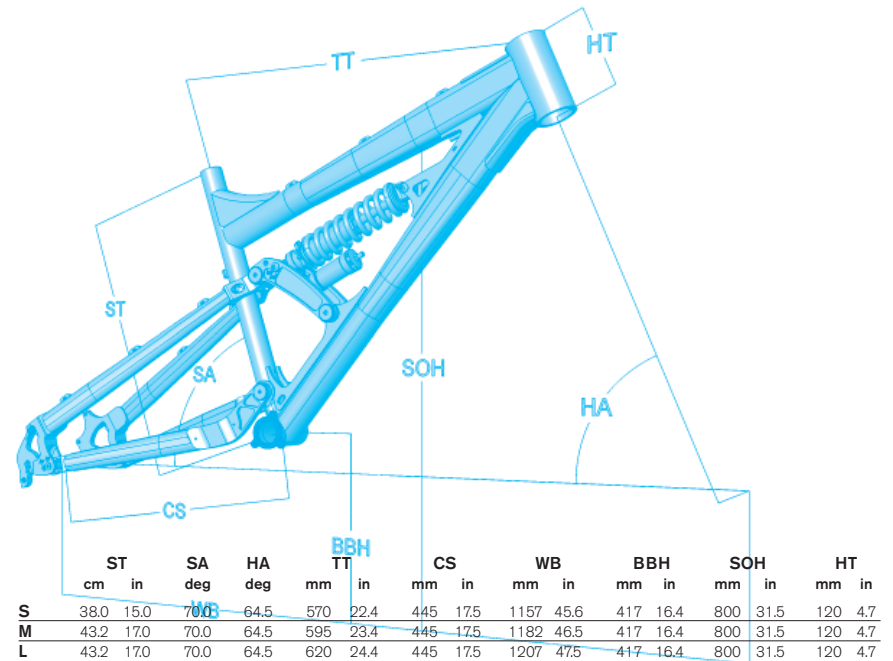

DEVINCI



DEVINCI.COM