

MOONRACER SL 2



FRAME	MOONRACER SL
SIZES	XS - S - M - L
FORK	FOX 32 F80 RL 80MM
REAR SHOCK	FOX FLOAT R
SHOCK PUMP	DEVINCI HIGH PRESSURE
HEADSET	FSA ORBIT MX
REAR DERAILLEUR	SHIMANO XT M760
FRONT DERAILLEUR	SHIMANO LX M581
CRANKSET	SHIMANO LX M580 44/32/22T
CHAIN GUIDE	-
FRONT SHIFTER	SHIMANO LX M585
REAR SHIFTER	SHIMANO LX M585
CASSETTE	SHIMANO LX M580 9S 11-32T
CHAIN	SHIMANO HG53
PEDALS	CRANK BROTHERS EGG BEATER MXR
FRONT WHEEL	SHIMANO LX M585 DISC / MAVIC XM317 / DT SWISS CHAMPION
REAR WHEEL	SHIMANO LX M585 DISC / MAVIC XM317 / DT SWISS CHAMPION
TIRES	MAXXIS LARSEN TT 26X2.0" 120TPI FOLDABLE
BRAKES	SHIMANO LX M585 160MM ROTOR HYDRAULIC DISC
STEM	V2 PRO 31.8MM
HANDLEBAR	V2 GYRO FLATBAR 31.8MM
GRIPS, TAPE	VELO GEL LOCK-ON
SADDLE	SELLE ITALIA X2 TRANS AM SPECIAL EDITION
SEATPOST	V2 PRO 27.2MM

MOONRACER SL

MOONRACER SL 2, MOONRACER SL 3, MOONRACER SL 4

This racing frame is the ultimate weapon of victory and will destroy the competition in any cross-country race. It has a rigid four-bar linkage suspension system, reinforced Optimum 2 aluminum tubes, thru-axle suspension pivots mounted on polymer bearings, shot-peened surfaces, and double-pass welds. This bike is tough, but at 2,190g, it's one of the lightest dual-suspension mountain frames around! For riders who mean business—the business of winning.

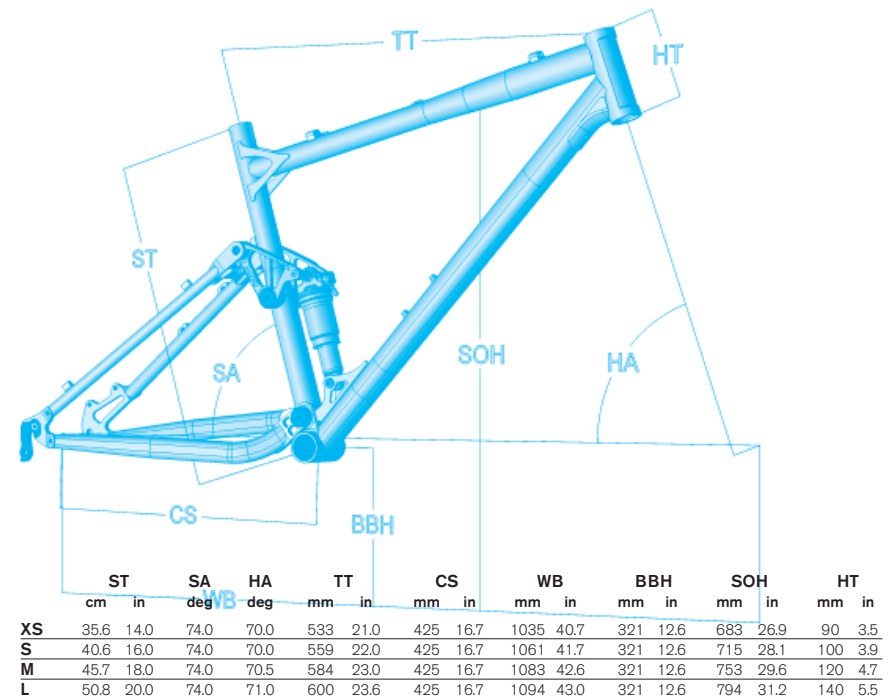

DEVINCI



devinciIntelligence

DEVINCI.COM