

COPENHAGEN



FRAME	HYBRID SL
SIZES	S - M - L - XL
FORK	DEVINCI CARBON AS WITH DISC BRAKE HANGER
REAR SHOCK	-
SHOCK PUMP	-
HEADSET	TH IS-3E
REAR DERAILLEUR	SHIMANO LX M581
FRONT DERAILLEUR	SHIMANO R443
CRANKSET	TRUVATIV TOURO 3.0 POWER SPLINE 52/42/30T
CHAIN GUIDE	-
FRONT SHIFTER	SHIMANO R440
REAR SHIFTER	SHIMANO R440
CASSETTE	SHIMANO HG50 9S 11-32T
CHAIN	SHIMANO HG53
PEDALS	WELLGO LU-981
FRONT WHEEL	FORMULA DC91-DC32 DISC / MACH 1 540 / DT SWISS CHAMPION
REAR WHEEL	FORMULA DC32 DISC / MACH 1 540 / DT SWISS CHAMPION
TIRES	KENDA KWEST PUNCTURE RESISTANT 700X32C
BRAKES	HAYES MX-2 XC 160MM MECHANICAL DISC
STEM	V2 PRO 31.8MM
HANDLEBAR	V2 GYRO RAISERBAR 31.8MM
GRIPS, TAPE	VELO GEL LOCK-ON
SADDLE	SELLE ITALIA XO TRANS AM
SEATPOST	V2 FUSION CARBON 27.2MM

HYBRID SL

MELBOURNE, SYDNEY, COPENHAGEN, AMSTERDAM, OSLO

From urban streets to bike paths, the completely redesigned 2007 hybrid is strong enough to take a serious beating on weekends and still provide a smooth ride to work. Optimum 2 tubes make this frame lighter and stronger than ever. And double bend stays add extra comfort on bumpy roads. The frame is designed to allow for disk brakes for amazing stopping power in traffic. Perfect for the urban rider who likes to bomb down hills on weekends.

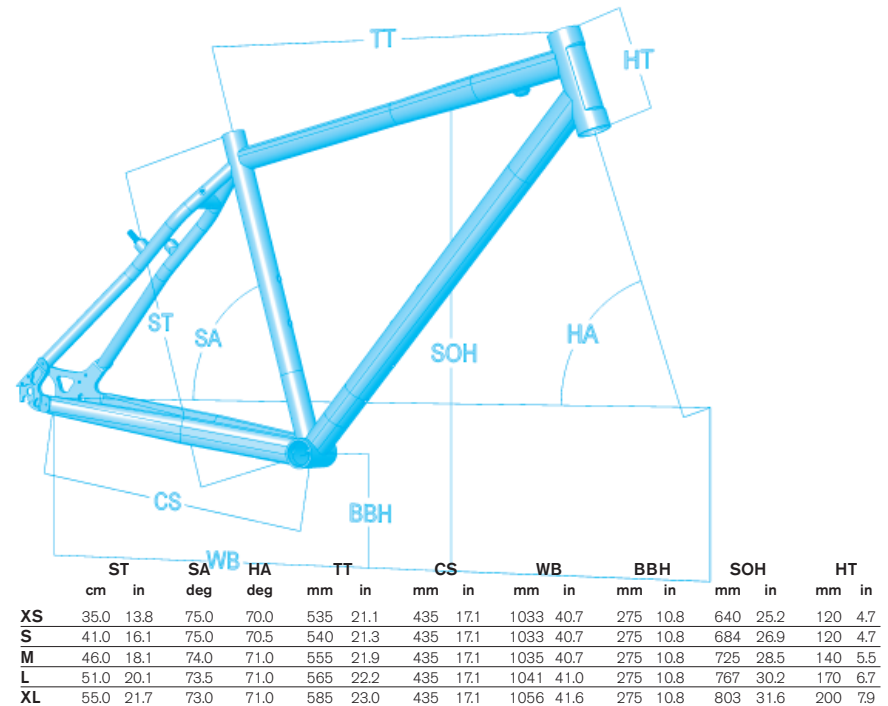

DEVINCI



devinciIntelligence

DEVINCI.COM