

# AMSTERDAM



<b>FRAME</b>	HYBRID SL
<b>SIZES</b>	XS - S - M - L - XL
<b>FORK</b>	DEVINCI CARBON AS WITH DISC BRAKE HANGER
<b>REAR SHOCK</b>	-
<b>SHOCK PUMP</b>	-
<b>HEADSET</b>	TH IS-3E
<b>REAR DERAILLEUR</b>	SHIMANO LX M581
<b>FRONT DERAILLEUR</b>	SHIMANO R443
<b>CRANKSET</b>	TRUVATIV TOURO 3.0 POWER SPLINE 52/42/30T
<b>CHAIN GUIDE</b>	-
<b>FRONT SHIFTER</b>	SHIMANO R440
<b>REAR SHIFTER</b>	SHIMANO R440
<b>CASSETTE</b>	SHIMANO HG50 9S 11-32T
<b>CHAIN</b>	SHIMANO HG53
<b>PEDALS</b>	WELLGO LU-981
<b>FRONT WHEEL</b>	FORMULA DC20-DC22 DISC / MADDUX DM21 / STAINLESS
<b>REAR WHEEL</b>	FORMULA DC22 DISC / MADDUX DM21 / STAINLESS
<b>TIRES</b>	KENDA KWEST PUNCTURE RESISTANT 700X32C
<b>BRAKES</b>	PROMAX TX-122
<b>STEM</b>	FSA OS-190LX 31.8MM
<b>HANDLEBAR</b>	V2 GYRO RAISERBAR 31.8MM
<b>GRIPS, TAPE</b>	VELO KRATON GEL
<b>SADDLE</b>	SELLE ITALIA XO TRANS AM
<b>SEATPOST</b>	FSA SL-280 27.2MM

## HYBRID SL

MELBOURNE, SYDNEY, COPENHAGEN, AMSTERDAM, OSLO

From urban streets to bike paths, the completely redesigned 2007 hybrid is strong enough to take a serious beating on weekends and still provide a smooth ride to work. Optimum 2 tubes make this frame lighter and stronger than ever. And double bend stays add extra comfort on bumpy roads. The frame is designed to allow for disk brakes for amazing stopping power in traffic. Perfect for the urban rider who likes to bomb down hills on weekends.

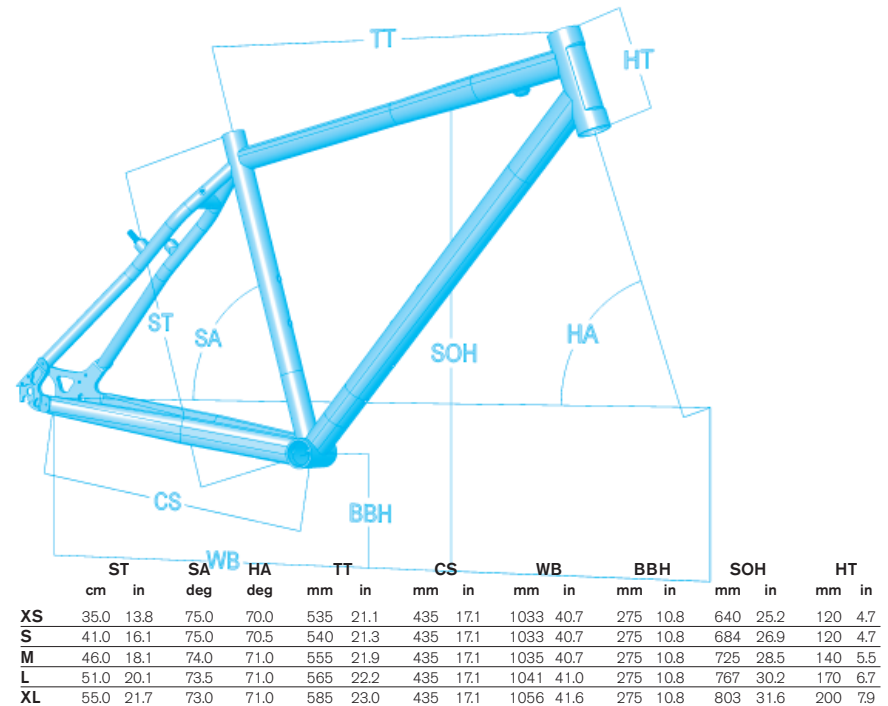

devinci



devinciIntelligence

DEVINCI.COM