

> MASSAI



Cycles Devinci >>>

Cross-Country

- 06** FV6500011 XXSmall
 FV6500111 XSmall
 FV6500211 Small
 FV6500311 Medium
 FV6500411 Large



SPECIFICATIONS

Frame	SGX 61 cross-country frame
Color	Rally Blue
Available Sizes	xxs-xs-s-m-l
Weight	13.9 kg / 30.6 lb
Fork	SR Suntour SF-XCT 75mm
Rear Shock	-
Headset	TH Industries No.11
Rear Derailleur	Sram SX 4.0
Front Derailleur	Sram 3.0
Crankset	Truvativ X-flow 42/32/22T
Chainguide	-
Shifters	Sram SX 4.0 trigger
Cassette	Sram PG-830, 11-32T
Chain	KMC IG-31
Bottom Bracket	Truvativ Power Spline
Pedals	VP 990S
Front Hub	Formula
Rear Hub	Formula
Rims	Alex ACE18
Spokes	Stainless
Wheels	-
Tires	Kenda K881 26x2.1" Front, K891 26*2.1 Rear
Brakes	Promax TX-122, V-brake
Brake Levers	Promax alliage
Stem	Globe Alloy
Handlebar	Alloy riserbar 30mm
Grips / Tape	Kraton
Saddle	Devinci double density
Seat Post	Globe Alloy micro adjust 27.2mm
Seat Collar	Devinci quick release

Notes



SGX 61 CROSS-COUNTRY FRAME

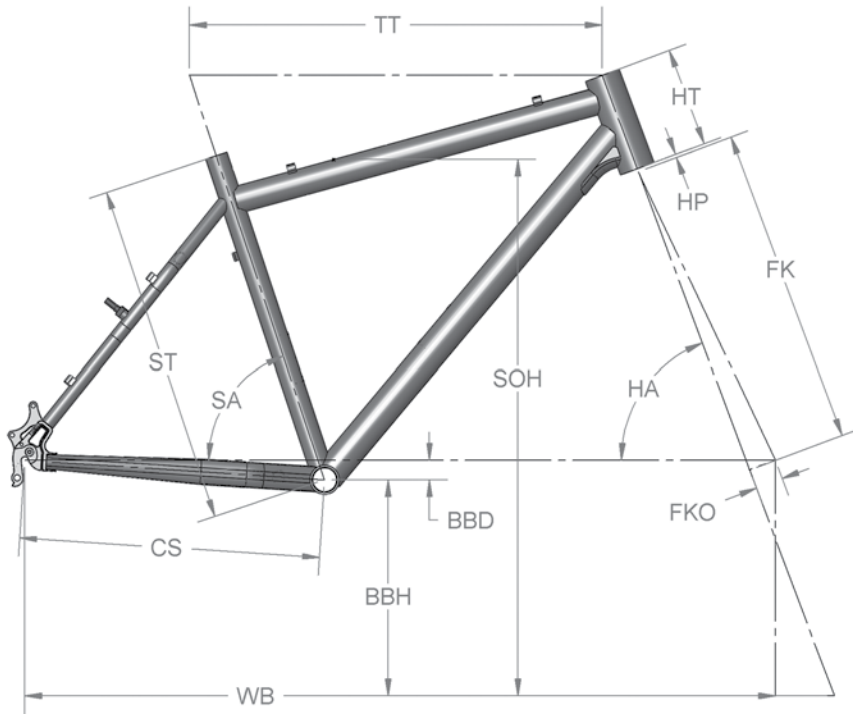

FRAME TECHNICAL SPECIFICATIONS

Seat post diameter	27.2 mm
Seat collar diameter	31.8 mm
Headset diameter	1 1/8"
Headset type	Semi-integrated
Fork type	100 mm
Brake type	"V-Brake"-Disk
Front derailleur diameter	31.8 mm
Front derailleur cable route	Top
Front derailleur type	Top-swing
Bottom bracket shell width	73 mm
Freehub width	135 mm
Shock length	NA
Shock travel	NA
Shock pivot width top	NA
Shock pivot width bottom	NA
Shock bolt diameter	NA
Rear wheel travel	NA
Tire maximum clearance	26 x 2.35
Rear derailleur hanger type	MFD205
Rear rack eyelet	Dropout
Fender eyelet	NA
Weight	1.83 kg / 4.03 lb

FRAME GEOMETRY

	ST		SA		HA		TT		CS		WB		BBH		SOH		HT		BBD		FK		FKO		HP	
	cm	in	deg	deg	mm	in	mm	in	mm	in	mm	in	mm	in	mm	in	mm	in	mm	in	mm	in	mm	in	mm	in
XXS	33.0	13.0	73.0	69.0	527.0	20.7	425.0	16.7	1024.0	40.3	306.0	12.0	664.0	26.1	100.0	3.9	28.0	1.1	450.0	17.7	39.0	1.5	5.0	0.2		
XS	38.1	15.0	72.5	69.0	530.0	20.9	425.0	16.7	1022.0	40.2	306.0	12.0	700.0	27.6	110.0	4.3	28.0	1.1	450.0	17.7	39.0	1.5	5.0	0.2		
S	43.2	17.0	72.5	69.0	556.0	21.9	425.0	16.7	1049.0	41.3	306.0	12.0	730.0	28.7	120.0	4.7	28.0	1.1	450.0	17.7	39.0	1.5	5.0	0.2		
M	48.3	19.0	71.5	69.5	582.0	22.9	425.0	16.7	1060.0	41.7	306.0	12.0	760.0	29.9	140.0	5.5	28.0	1.1	450.0	17.7	39.0	1.5	5.0	0.2		
L	53.3	21.0	71.0	70.0	608.0	23.9	425.0	16.7	1075.0	42.3	306.0	12.0	800.0	31.5	160.0	6.3	28.0	1.1	450.0	17.7	39.0	1.5	5.0	0.2		

SIZING CHART

Height (cm)	131	134	136	138	140	142	144	146	148	150	152	154	157	159	161	163	165	168	170	172	174	176	178	180	182	184	186	188	190	
Inseam (cm)	62	63	64	65	66	67	68	69	70	71	72	73	74	75	76	77	78	79	80	81	82	83	84	85	86	87	88	89	90	
XXS																														
XS																														
S																														
M																														
L																														
Height (inch)	4'4"	4'5"	4'5"	4'6"	4'7"	4'8"	4'8"	4'10"	4'11"	4'11"	5'0"	5'1"	5'1"	5'2"	5'3"	5'4"	5'5"	5'6"	5'7"	5'7"	5'8"	5'9"	5'10"	5'11"	6'0"	6'0"	6'1"	6'2"	6'3"	
Inseam (inch)	24½	24¾	25¼	25½	26	26½	26¾	27¼	27½	28	28¼	28¾	29¼	29½	30	30¼	30¾	31	31½	32	32¼	32¾	33	33½	33¾	34¼	34¾	35	35½	

TO MEASURE INSEAM

You must be standing on a hard surface, in bare feet (or light cycling socks). Ideally, you will be wearing cycling shorts or long tights.

Place the feet so the medial ankle bones are approximately 5 cm apart. This can easily be gauged by slipping the width of the measuring tape case between the ankle bones.

The metric tape should be centered in the crotch. With the tape firmly in the crotch, pull with about the same pressure that you would feel if you were sitting on a bicycle seat. Pull the measuring tape to the floor for the inseam measurement.

TO MEASURE HEIGHT

You must be standing on a hard surface, in bare feet (or light cycling socks).

Place the feet so the medial ankle bones are approximately 5 cm apart. This can easily be gauged by slipping the width of the measuring tape case between the ankle bones.

